

MMBT2222A

NPN General Purpose Amplifier

Features

- Surface Mount SOT-23 Package
- Capable of 350mWatts of Power Dissipation

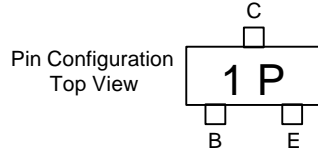

Electrical Characteristics @ 25°C Unless Otherwise Specified

Symbol	Parameter	Min	Max	Units
OFF CHARACTERISTICS				
$V_{(BR)CEO}$	Collector-Emitter Breakdown Voltage* ($I_C=10\text{mAdc}$, $I_B=0$)	40		Vdc
$V_{(BR)CBO}$	Collector-Base Breakdown Voltage ($I_C=10\mu\text{Adc}$, $I_E=0$)	75		Vdc
$V_{(BR)EBO}$	Emitter-Base Breakdown Voltage ($I_E=10\mu\text{Adc}$, $I_C=0$)	6.0		Vdc
I_{BL}	Base Cutoff Current ($V_{CE}=60\text{Vdc}$, $V_{BE}=3.0\text{Vdc}$)		20	nAdc
I_{CEX}	Collector Cutoff Current ($V_{CE}=60\text{Vdc}$, $V_{BE}=3.0\text{Vdc}$)		10	nAdc

ON CHARACTERISTICS

h_{FE}	DC Current Gain* ($I_C=0.1\text{mAdc}$, $V_{CE}=10\text{Vdc}$) ($I_C=1.0\text{mAdc}$, $V_{CE}=10\text{Vdc}$) ($I_C=10\text{mAdc}$, $V_{CE}=10\text{Vdc}$) ($I_C=150\text{mAdc}$, $V_{CE}=10\text{Vdc}$) ($I_C=150\text{mAdc}$, $V_{CE}=1.0\text{Vdc}$) ($I_C=500\text{mAdc}$, $V_{CE}=10\text{Vdc}$)	35		
		50		
		75	300	
		100		
		40		
$V_{CE(sat)}$	Collector-Emitter Saturation Voltage ($I_C=150\text{mAdc}$, $I_B=15\text{mAdc}$) ($I_C=500\text{mAdc}$, $I_B=50\text{mAdc}$)		0.3 1.0	Vdc
$V_{BE(sat)}$	Base-Emitter Saturation Voltage ($I_C=150\text{mAdc}$, $I_B=15\text{mAdc}$) ($I_C=500\text{mAdc}$, $I_B=50\text{mAdc}$)	0.6	1.2 2.0	Vdc

SMALL-SIGNAL CHARACTERISTICS

f_T	Current Gain-Bandwidth Product ($I_C=20\text{mAdc}$, $V_{CE}=20\text{Vdc}$, $f=100\text{MHz}$)	300		MHz
C_{obo}	Output Capacitance ($V_{CB}=10\text{Vdec}$, $I_E=0$, $f=1.0\text{MHz}$)		8.0	pF
C_{ibo}	Input Capacitance ($V_{BE}=0.5\text{Vdc}$, $I_C=0$, $f=1.0\text{MHz}$)		25	pF
NF	Noise Figure ($I_C=100\mu\text{Adc}$, $V_{CE}=10\text{Vdc}$, $R_S=1.0\text{k}\Omega$, $f=1.0\text{kHz}$)		4.0	dB

SWITCHING CHARACTERISTICS

t_d	Delay Time	($V_{CC}=30\text{Vdc}$, $V_{BE}=0.5\text{Vdc}$)	10	ns
t_r	Rise Time	($I_C=150\text{mAdc}$, $I_{B1}=15\text{mAdc}$)	25	ns
t_s	Storage Time	($V_{CC}=30\text{Vdc}$, $I_C=150\text{mAdc}$)	225	ns
t_f	Fall Time	($I_{B1}=I_{B2}=15\text{mAdc}$)	60	ns

*Pulse Width $\leq 300\mu\text{s}$, Duty Cycle $\leq 2.0\%$

SOT-23

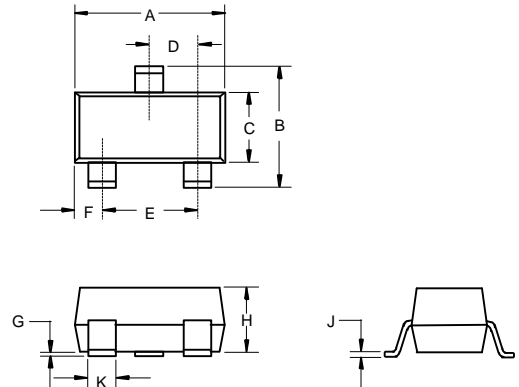

DIM	INCHES		MM		NOTE
	MIN	MAX	MIN	MAX	
A	.110	.120	2.80	3.04	
B	.083	.098	2.10	2.64	
C	.047	.055	1.20	1.40	
D	.035	.041	.89	1.03	
E	.070	.081	1.78	2.05	
F	.018	.024	.45	.60	
G	.0005	.0039	.013	.100	
H	.035	.044	.89	1.12	
J	.003	.007	.085	.180	
K	.015	.020	.37	.51	

Suggested Solder Pad Layout

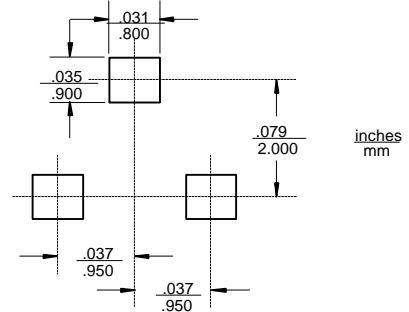

MMBT2222A

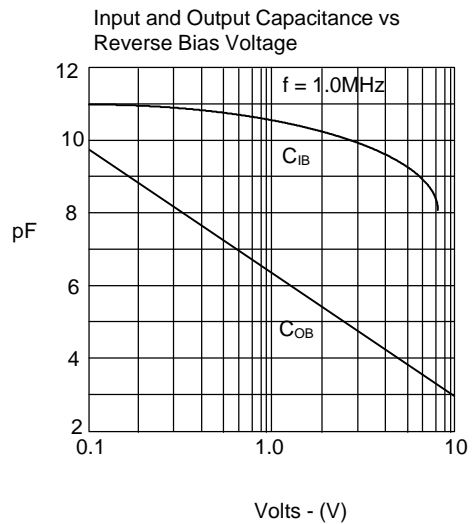
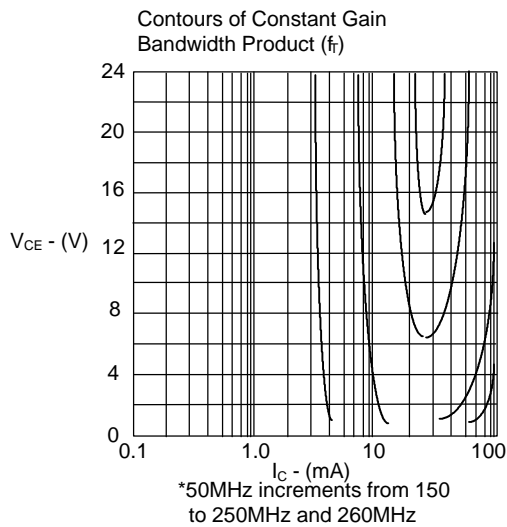
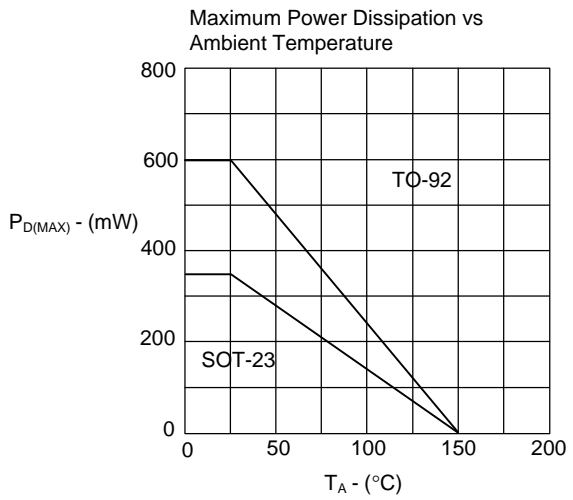
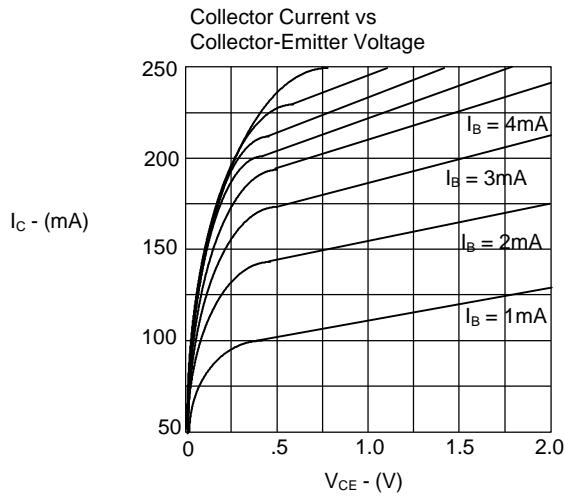
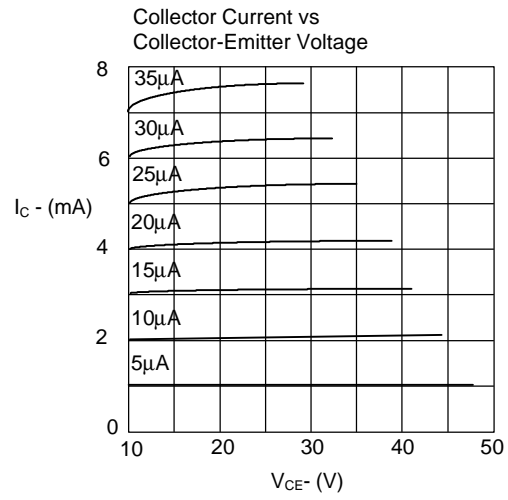
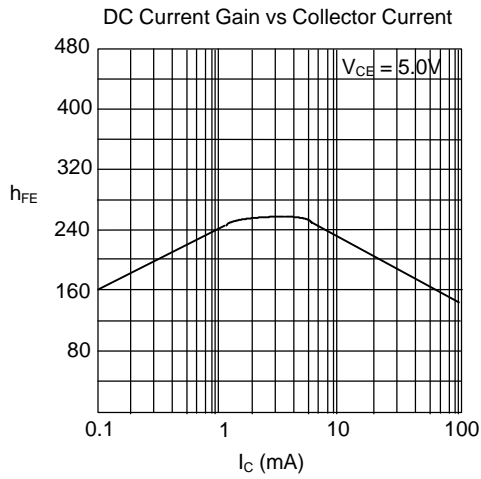

MMBT2222A

